

Frame Information

GJ1P Series



Eaton Corporation's Heinemann GJ1P breakers offer high-quality circuit protection for dc applications from 100 to 1200 amperes.

Their precisely tailored time delays and ability to interrupt high currents makes them ideally suited for critical applications. On overloads exceeding 1000 – 1400% of rating, there is no intentional time delay and the breaker interrupts currents of as much as 100,000 amperes at 65 Vdc up to 1200 amperes.

An optional shunt (25 or 50 millivolt full scale) permits metering of current. Since the shunt output is low voltage, light-gauge wiring can be used from shunt to meter. Indication may be displayed in percent, watts, safe/danger or other dial calibrations. In addition, the bus bar is available in two versions, Standard Size and Reduced Size. Contact your Eaton sales representative for more information.

Precision Current Equalization (PCE) Circuit Breakers

GJ1P breakers rated 250 to 1200 amperes are built in parallel construction.

Conventional parallel pole breakers can experience uneven current distribution because of variations in internal resistances. This condition can result in nuisance tripping since the higher current in one parallel branch has the same effect as an overload on the sensing element in that branch. Proprietary Precision Current Equalization (PCE) circuit breakers, on the other hand, allow for differences in internal resistances by automatically distributing the current equally through the parallel current sensing elements, minimizing the danger of nuisance tripping.

The UL listed series GJ1P (UL 489) models are available in a choice of fast, medium or slow response times to accurately match load conditions.

They can be ordered in "series trip," "mid-trip" and "switch only" constructions and are available front- or back-mounted, front- or back-connected, with optional auxiliary switches for signaling.

BASIC DIMENSIONS

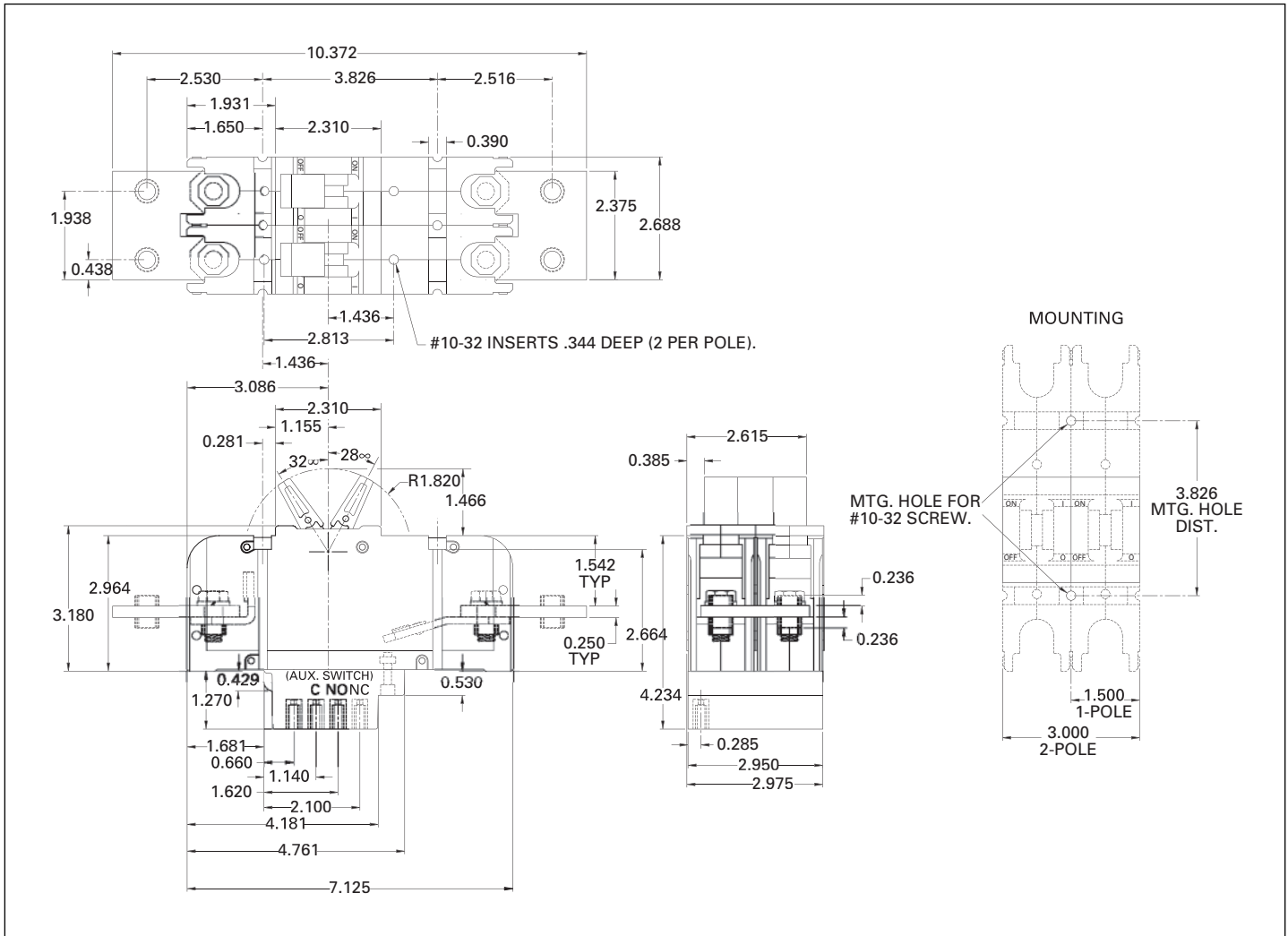

GJ1P CATALOG NUMBERING SYSTEM

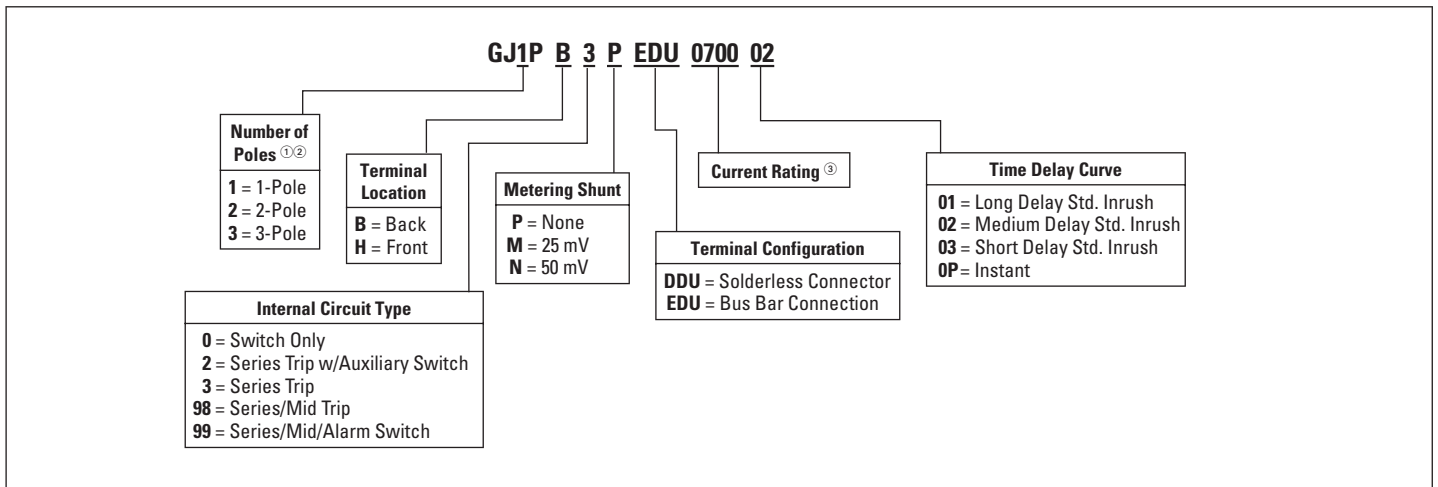

① Select from 1 to 3 poles, and enter the number in position 3 of the catalog number. For example, a GJ1P would identify a 1-pole GJ Series breaker.
 ② Style includes Toggle Handle with Black ON/OFF handle color and 6-32 mounting.
 ③ Enter the four digit current rating. For example, use code "0015" for a 15 ampere current rating. Breakers are available from 100 – 280 amperes.