

Medical Base Mounting and Bulkhead

BASE MOUNTING

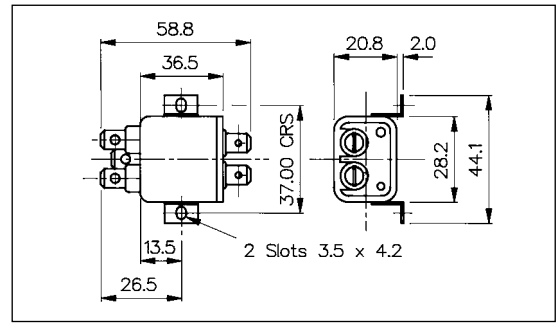

- 1, 3, 6 or 10 Amp Current Rating
- Medical
- 3 Alternative Circuits
- Optional Additional Components
- 2.8 or 6.3mm tabs



BULKHEAD MOUNTING



- 1, 3, 6 or 10 Amp Current Rating
- Medical
- 3 Alternative Circuits
- Optional Additional Components
- 2.8 or 6.3mm tabs

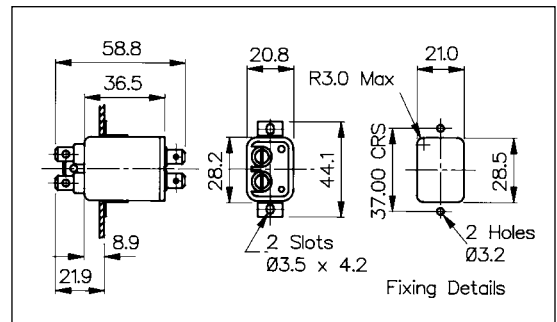

IEC CONNECTORS

PS02 or PS03/Bxx xx /xx

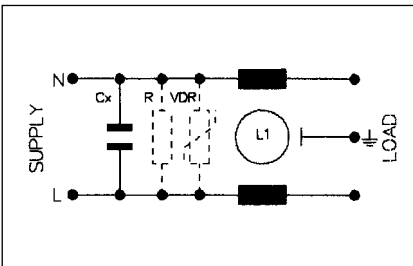

Series	Rating	L/C Circuit	Additional Components	Tag Type and Configuration
PS02/B	01 = 1A	1 = Version 1	0 = None	28 = 2.8mm
PS03/B	03 = 3A	2 = Version 2	1 = Bleed (R) Resistor	63 = 6.3mm tabs
	06 = 6A	3 = Version 3	2 = Surge (VDR) Protection	
	10 = 10A		3 = "R" plus "VDR"	

Specification	PS02/Bxxxx/xx	PS03/Bxxxx/xx	Part No. Example
Max. Working Voltage:	250V a.c. 50-400Hz	250V a.c. 50-400Hz	PS03/B0630/63 = PS03 series, bulkhead mounting for medical applications, rated at 6 amperes. L/C circuit version 3, i.e. L1 = 2 x 0.7mH, Cx = 47nF, without bleed resistor or surge protection device fitted, with 6.3mm tabs.
Earth Leakage Current:	<100µA (typically 5µA 250V, 50Hz)	<100µA (typically 5µA 250, 50Hz)	
Temperature Range:	-25°C to +85°C	-25°C to +85°C	
Max. Ambient Temp.: (@ Full Load)	40°C (derate linearly to 0A @ 85°C)	40°C (derate linearly to 0A @ 85°C)	
Test Voltage:	2700V d.c. 2 secs. Lines to Earth 1100V d.c. 2 secs. Live to Neutral	2700V d.c. 2 secs. Lines to Earth 1100V d.c. 2 secs. Live to Neutral	
Approvals:			
	Compliant	Compliant	

Rating & Version Table

PS02/Bxxxx/xx & PS03/Bxxxx/xx

Rating	Version	L1	Cx
1 AMP	1	2 x 2.8mH	1 x 15nF
"	2	2 x 10mH	1 x 15nF
"	3	2 x 10mH	1 x 47nF
3 AMP	1	2 x 0.75mH	1 x 15nF
"	2	2 x 1.8mH	1 x 15nF
"	3	2 x 1.8mH	1 x 47nF
6 AMP	1	2 x 0.3mH	1 x 15nF
"	2	2 x 0.7mH	1 x 15nF
"	3	2 x 0.7mH	1 x 47nF
10 AMP	1	2 x 0.17mH	1 x 15nF
"	2	2 x 0.35mH	1 x 15nF
"	3	2 x 0.17mH	1 x 47nF

IEC CONNECTORS

Version 1

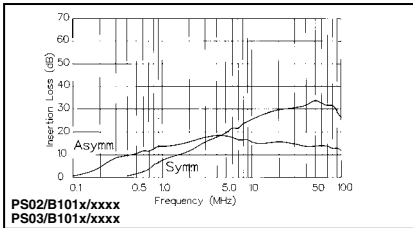
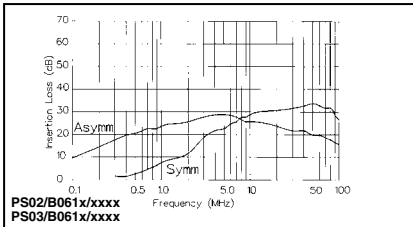
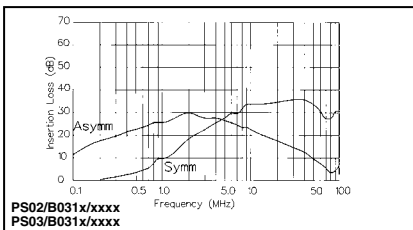
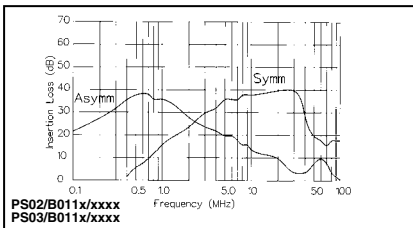

Version 2

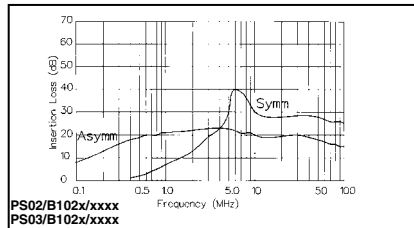
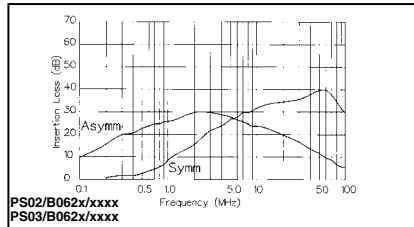
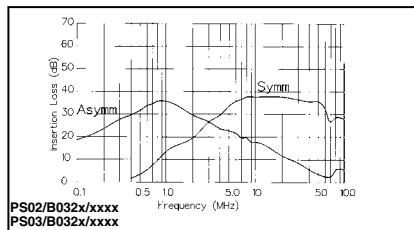
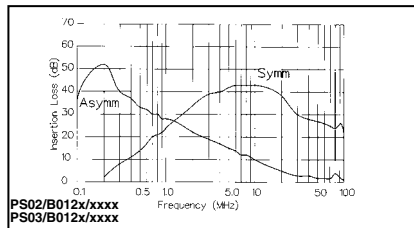

Version 3

